

System 4.5 High Performance Ultra-Compact Home Theater Loudspeaker System



Covers Models 4.5 LR, 4.5 C, and 4.5 SR

 **Atlantic Technology**[®]
INNOVATIVE HOME THEATER

343 Vanderbilt Avenue Norwood, MA 02062 (781) 762-6300 www.atlantictechnology.com

Instruction Manual

SYSTEM 4.5

High Performance Ultra-Compact Home Theater Loudspeaker System



Thank you for choosing Atlantic Technology home theater products. Your new speaker system is precision crafted to give you years of enjoyable, trouble free service. This manual covers the Atlantic Technology System 4.5 series of speakers for home theater. It will show you how to incorporate the following System 4.5 components into your present setup, as well as how to assemble a complete system. The Model 4.5 PBM Subwoofer is covered in detail in a separate manual. System 4.5 has been optimized for use with any surround sound format including Dolby Surround®, Dolby Pro-Logic®, Dolby Digital 5.1® and DTS® digital surround formats.

Model 4.5 LR Front Channel Speaker

The **Model 4.5 LR Front Channel Speakers** are two-way systems including a built-in high pass filter at 125 Hz, intended for use with a quality subwoofer, such as the Atlantic Technology Model 4.5 PBM. Each speaker contains two 3 1/2" IMG (injection-molded graphite) woofers, and a 1" Ferrofluid® cooled silk dome tweeter using a powerful neodymium magnet, in an acoustically inert MDF cabinet.

Model 4.5 C Center Channel Speaker

It is vital to the accurate reproduction of a multi-channel soundtrack that the three front speakers have the same sonic signature. Therefore, the **Model 4.5 C Center Channel Speaker** contains the same two 3 1/2" IMG woofers, 1" Ferrofluid® cooled silk dome tweeter, and built-in 125 Hz high pass filter as the 4.5 LR speakers. The 4.5 C is designed for use in home theater systems that use a dedicated center channel speaker. This speaker incorporates unique compensation circuitry that allows it to be placed directly above or below the TV screen and still provide accurate reproduction. Since up to 85% of the movie soundtrack is reproduced through the center channel speaker, it is important that its sound be accurate and timbre-matched to the other speakers in the system. The unique rear-mounted high frequency control incorporated in the 4.5 C allows virtually perfect matching.

To further optimize the performance of the three front channels, all the drivers in the 4.5 LR's and 4.5 C are mounted to a solid machined aluminum plate. This mounting system eliminates undesirable resonances and helps focus the tweeter's sound to provide precise image placement and wide dispersion.

Model 4.5 SR Surround Speaker

The Model 4.5 SR Surround Speaker is intended for use in audio/video sound systems with dedicated surround channel speakers. Each speaker has two 3 1/2" IMG woofers, as well as two 3/4" fabric dome tweeters which are angled and phased to produce ambience without localization. Its wide bandwidth and unique construction makes it especially suitable for Dolby Digital and DTS applications. Please note that there is a dedicated LEFT and RIGHT model 4.5 SR. This is clearly marked on the back of each speaker.

Note: *The 4.5 SR is not intended for use as a regular right and left front channel stereo speaker or satellite. Its spatial performance characteristics are simply not appropriate for this purpose. In the Atlantic Technology 4.5 Series of components, the Model 4.5 LR fills this role.*

Although the speakers in the Atlantic Technology System 4.5 are acoustically and cosmetically matched to each other for best results, they may also be used with a wide variety of speakers from other manufacturers with satisfying results.

Connecting Your System

We recommend that you connect your System 4.5 speaker systems with high quality dual conductor stranded wire of 18 gauge or larger, for lengths up to 25 feet. Use 16 gauge dual conductor or larger for longer runs of wire. Contact your local audio/video specialist for specific cable recommendations and further information for special circumstances.

Warning: *To prevent risk of electrical shock or damage to your equipment, always switch off the amplifier or receiver when making connections to the speaker.*

You can connect your System 4.5 speakers by using a variety of audio connectors, or you can:

1. Remove 1/2" of insulation from each wire end.
2. Twist the stranded wire together, keeping the two ends separate.
3. Place the appropriate wire through the appropriate postholes in the connectors. These holes are revealed when you loosen the connector thumbscrew.
4. Screw down the thumbscrew tightly.

We recommend that you check your local electrical codes to make sure that you are not using an improper connector.

Figure 1:
Gold plated
5-way binding
posts. Accepts
up to 10 gauge
bare wire

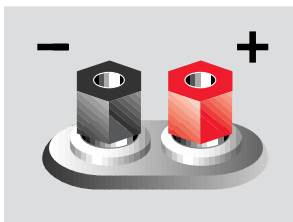

It is important to observe polarity while making speaker connections: red (+) terminals on the amplifier to red (+) on the speaker, black (-) on the amplifier to black (-) on the speaker. Look carefully at the wires you are using and note that one of conductors of each pair is marked by a different color, printing, ridges, or a thread intertwined with the wire strands. By convention, the marked wire is connected to the red (+) terminal.

Whether you are connecting a complete System 4.5, or adding a single speaker component to your present system, the wiring should look like the diagram in Figure 2.

Figure 2:
Typical wiring
diagram for
speakers in a
home theater.

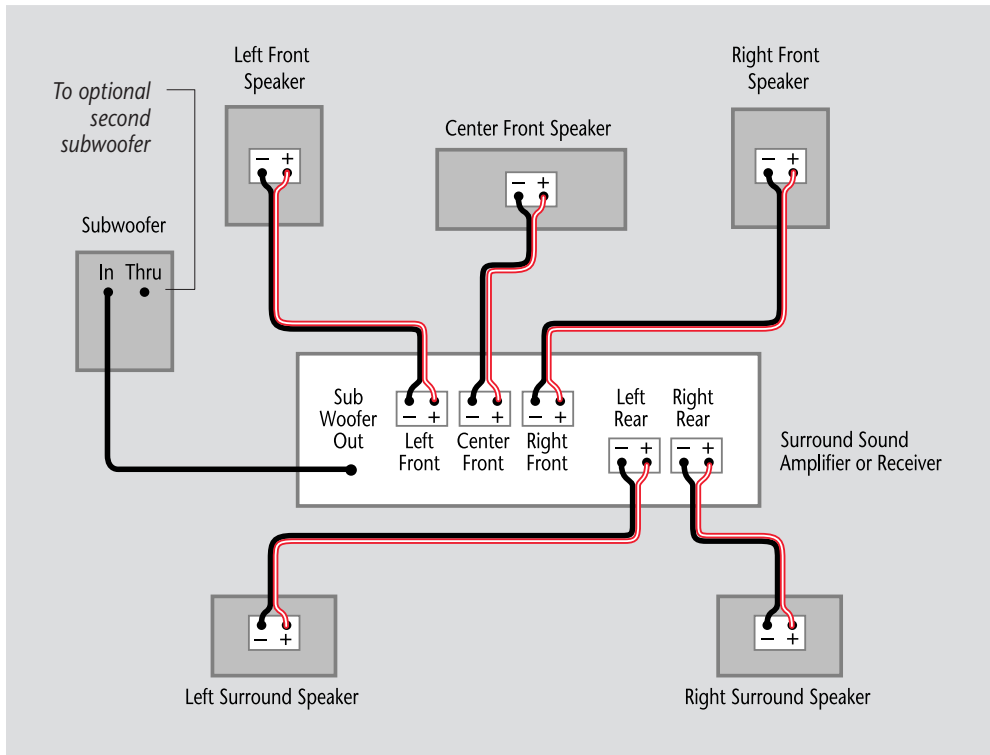

Warning: Before turning on the amplifier, be certain that no stray wire strands are touching across the two terminals as this might damage your amplifier.

Finally, check the polarity of your front speakers by listening to some music. If the sound seems hollow, unusually spread out, or has weak bass, recheck your connections for proper polarity. If necessary, reverse any out of phase connections. Only one speaker wired out of phase is usually the culprit.

Placement and Operation

Speaker/room interactions have a huge impact on the sound of the system. Moving the speakers just a little bit can make a dramatic difference in what you hear. The ultra-compact design of System 4.5 provides you with maximum placement flexibility while creating a large, seamless, acoustically accurate soundfield for your home theater or music system. The best placement of the speakers will vary from room to room. Use the following placement guidelines and Figure 3 as a starting point. But also feel free to experiment. In fact, it may be beneficial to hook up the speakers with some extra wire and to simply drape the wire across the floor before installing the speakers permanently. This will allow you the opportunity to move the speakers around easily so you can find the best sonic and visual locations.

Figure 3: Typical arrangement for speakers in a home theater. For best results, place the surround speakers within the shaded area. Note that the surround speakers are marked **Left** and **Right**. It is important that the speakers be placed correctly for proper imaging.

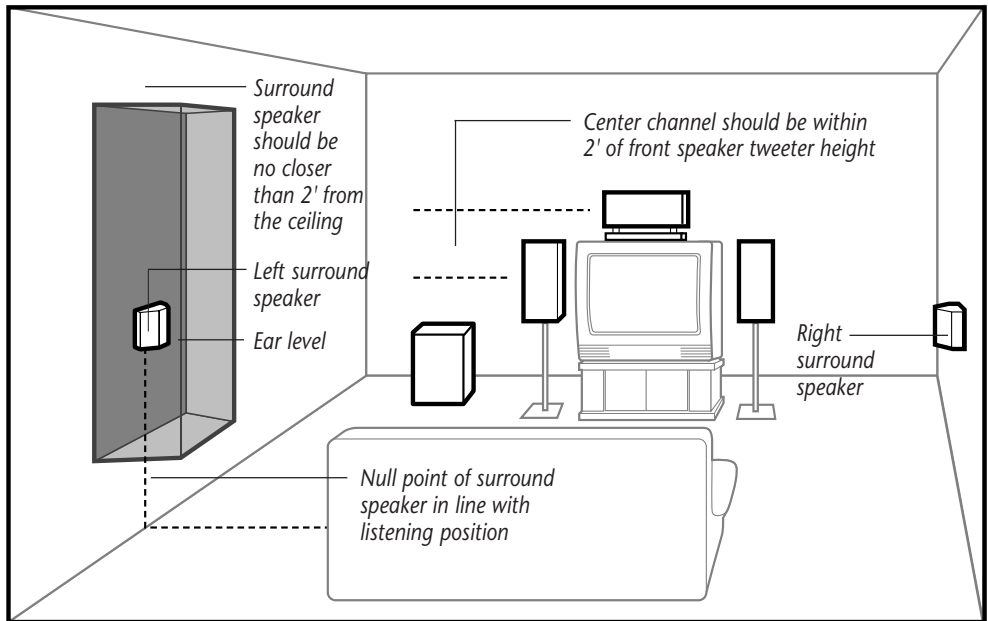

Home Theater

Remember that the primary goal of a good Home Theater is not to make you believe that you are in a movie theater. It's to make you believe you are in the scene taking place on the screen. For a Home Theater system, place your Model 4.5 LR speakers on either side of the television. The three front channel speakers (4.5 LRs and 4.5 C) are magnetically shielded so they will not interfere with your television picture. The left front and right front speakers should be far enough apart that you get a good stereo image, but not so far apart that the sound seems to come directly from the speakers, distracting you from the picture. If you are using a center channel speaker, a wider separation of the left and right front speakers is usually possible. You may choose to "toe" the LR speakers in, aiming them at the prime listening position. This can be particularly useful if the front LR speakers are fairly far apart.

The Model 4.5 C should be placed directly above or below your television. It is important that the speaker is centered on the screen, not off to the side. Place the speaker base so that the foot cutouts are facing forward. Then pivot the speaker on its base, tilting it so that it points most directly at the listening position.

Operation of the HI FREQ LEVEL Control

Figure 4: Hi-Freq Level Control on rear panel of the Model 4.5 C.



The HI FREQ LEVEL control will give you more or less high frequency output from the speaker, working similarly to the treble tone control on a preamp, amp or receiver. This allows you to compensate for overly bright soundtracks or "punch up" a dull soundtrack. Turning this control clockwise increases the high frequency level; turning it counterclockwise reduces the high frequency level. The HI FREQ LEVEL control also will allow you to adjust the overall sonic balance of the 4.5 C to more closely match the LR speakers, even though the 4.5 C is placed directly above or below the TV screen.

Note: Some surround sound decoders and receivers offer a choice of “normal” or “wide-band” modes for the center channel. The Model 4.5 C was designed to be used in the “normal” mode. Additionally, some discrete digital Home Theater systems allow you to select between “Small” and “Large” speakers throughout the system. Since System 4.5 has been designed only to work with an active subwoofer, you should usually set all the speaker positions to “Small.” However, if you are using the 4.5 PBM subwoofer, please follow the connection instructions contained in the subwoofer manual.

Surround Effects

The 4.5 SR’s size and shape allows greater flexibility in placement than most conventional surround loudspeakers. Due to their dipole design’s spatial characteristics, it is possible to place the speakers virtually anywhere, but usually the best location is straight out to the sides of, or slightly behind the primary listening area, approximately 1-2 feet above ear level.

Note: The surround speakers are intended to re-create the ambient sounds taking place in the movie scene. Throughout most of a movie or TV program you may not be directly aware of the surround speakers presence. The signals they receive are mostly subtle sounds that should make you believe you’re in the movie.

The orientation of the 4.5 SR’s is important to the proper generation of the involving and diffuse surround effect. Mount each speaker on the wall or shelf so that the “direct” soundfield is aimed toward the front of the room, and the “ambient” soundfield is directed toward the rear. To insure this orientation, make sure that the RIGHT speaker is on the right side wall of the room, and the LEFT speaker is on the left side wall of the room. They are marked RIGHT and LEFT on the back.

Music Only System (Model 4.5 LR with subwoofer only)

If you are setting up a music only system, begin with these general guidelines:

- The distance between your speakers should be approximately one-half their distance from your favorite listening position.
- Point the front of the speakers straight at you to achieve the most precise imaging. You will also receive the maximum amount of direct radiated high frequency energy. If you have a “bright” or “hard” sounding room environment aiming the speakers straight out into the room (or just aiming them partially towards you) may make for a more natural and pleasing sonic balance.
- The distance from each speaker to its three closest room surfaces should be different.
- In most rooms, you should not place your speakers in the corners.

The goal is to reproduce accurate musical timbre, and natural sound. Additionally, a well set-up stereo pair of speakers will create excellent imaging and a cohesive representation of the soundstage. Placement in the room and your listening position have an enormous impact on the ultimate sound you will achieve from your system. The most important thing is to be creative! Try placing your speakers along the long wall instead of the short one. Toe the speakers in or point them straight ahead. Pull them away from the wall or push them close. Don't be timid. You'll find that moving your speakers, even a few inches, can dramatically change and possibly improve their sound.

Mounting

The 4.5 LR and the 4.5 SR speakers can be mounted in a variety of ways:

On speaker stands: Atlantic Technology speaker stands provide an ideal height (29" above the floor) for most rooms. They are available in black or white. Speaker stands from other manufacturers may be used, but should be of approximately the same height (29" to the base of the speaker).

On the wall: To mount your speakers on a wall, we have installed metal key-hole brackets on the back of the 4.5 LR and 4.5 SR speakers. Be sure to use a strong screw whose head and shaft will fit within the keyhole opening and slot. Also be sure to drive the screw well into a stud or use a mounting device (such as a molly-bolt) that is capable of holding the weight of the speaker. Never simply drive a nail or screw into a sheet rock or other wall materials. Always follow the above guidelines for safe speaker mounting.

For greatest flexibility, use pivoting ball-and-socket wall brackets of suitable weight rating (e.g., Omnimount 25 Series, Vogel, etc.) usually available from your local audio/video retailer.

On a bookshelf: Adhesive rubber feet are included.

In the wall: An optional Atlantic Technology in-wall mounting kit is available. It includes all the necessary hardware and trim to install a pair of 4.5 SR speakers recessed partially in a standard wall. Please contact your local Atlantic Technology dealer for further information.

Listening Levels and Power Handling – IMPORTANT!

The power recommendation for these speaker components assumes that you will not operate your amplifier/receiver in a way that produces distortion. Even rugged speakers like System 4.5 can be damaged by a moderately powered system driven beyond its intended capacity. The harsh amplifier clipping that occurs in this situation will cause damage to the speaker system. This type of damage is easily identifiable through examination of the damaged speaker's voice coil and is not covered by the warranty. The System 4.5 will play very loudly when provided with enough clean power to do so. Again, consult your dealer or Atlantic Technology for additional information.

Care and Feeding of Your Speakers

Clean your speaker cabinets using a soft cloth moistened with a mild, non-abrasive glass cleaner being careful not to wet the edges of the cabinet. Also, be careful not to get any cleaning fluids on the driver cones or domes. It may be best to dampen the cloth with the cleaner and then wipe the speakers. Use a soft cloth, but do not use any paper products, because no matter how soft they may feel, they will scratch the finish. After carefully removing the grilles from the speakers, clean them with a quick pass from a vacuum cleaner with a brush attachment. This should remove any dust accumulation. Avoid placing your speakers in direct sunlight or near a source of heat that may, over time, damage the finish.

Important: Save Your Boxes! *If possible, save the cartons, packing pieces, and plastic bags that came with your speakers. They will be useful in case you move or have to ship your loudspeakers for any reason. In any case, save all packing materials until you are certain that the systems have suffered no damage in shipment. If you find such damage, either visible or internal, contact your dealer immediately for the proper return procedure.*

System 4.5 Specifications

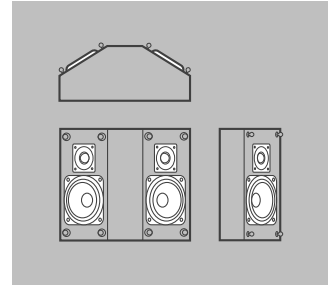
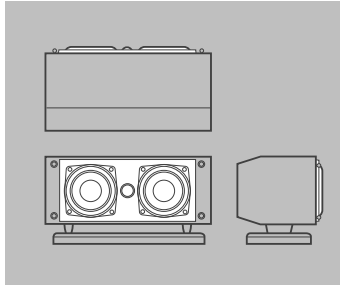
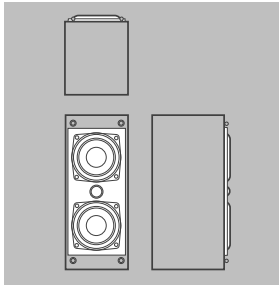

Model	4.5 LR	4.5 C	4.5 SR
Type	Sealed-box, 2-way	Sealed-box, 2-way, w/ High Frequency control	Sealed-box, spatially-enhanced surround speaker
Drivers	(2) 3-1/2" IMG woofers (1) 1" silk dome tweeter	(2) 3-1/2" IMG woofers (1) 1" silk dome tweeter	(2) 3-1/2" IMG woofers (2) 3/4" silk dome tweeters
Frequency Response (± 3 dB)	125Hz – 20kHz	125Hz – 20kHz	125Hz – 20kHz
Nominal Impedance	8 Ω	8 Ω	8 Ω
Crossover Frequency	3.5kHz	3.5kHz	3.5kHz
Sensitivity	88dB	88dB	88dB
Recommended Amplifier Power	10 – 125 Watts	10 – 125 Watts	10 – 125 Watts
Magnetic Shielding	Yes	Yes	No
Size (W x H x D)	4.53 x 10.43 x 6.3in 115 x 265 x 160mm	10.43 x 5.20 x 6.3in with base 265 x 132 x 160mm with base	8.66 x 7.87 x 4.92in 220 x 200 x 125mm
Weight (ea., unpacked)	6.5lbs; 2.8kg	6.7lbs; 3.04kg w/base	10.5lbs; 2.49kg

Specifications are those in effect at the time of printing. Atlantic Technology reserves the right to change specifications or appearance at any time without notice. Dolby Digital, AC-3, 5.1, Dolby Stereo and Dolby Pro Logic are trademarks of Dolby Laboratories Licensing Corporation. DTS is a registered trademark of DTS Technology.

For Future Reference

Record your speaker(s) serial number(s) and date of purchase here:

Model Number _____ Serial Number _____ Date of Purchase _____

Model Number _____ Serial Number _____ Date of Purchase _____

Model Number _____ Serial Number _____ Date of Purchase _____

The serial number is found on the back of the speaker near the connecting terminals.

